



Scene application requirements

Hotel	████████████████████
Restaurant	████████████████████
Fast food	████████████████████
Bar	████████████████████
Disco	████████████████████
Fish market	██████████
Supermarket	████████████████████
Ice cubes Sales	████████████████████
Medical & Spa	████████████████████
Industry	████████████████████

Self-contained ice maker system Daily production up to 70kg

This all-in-one ice maker redefines commercial and premium ice production with its distinctive crescent-shaped ice cubes. Combining efficient ice-making with elegant design, it is crafted to deliver crystal-clear, slow-melting crescent ice—the perfect choice for refined beverages. The crescent ice features a unique curved form that fits snugly against the glass, unlike traditional cube ice. This design not only ensures slower melting but also keeps drinks cooler longer without diluting their flavor. The graceful, shimmering arc of the crescent catches the light with a soft glow, making it a visual highlight whether used in classic cocktails, neat whiskey, iced coffee, or creative milk tea. Ideal for bars, specialty coffee shops, modern tea houses, and outdoor weddings.



Output:70kg/24h Color:Stainless steel

Features & Plus

- Automatic water intake and low water alarm
- Ice making will automatically stop when the ice is full
- Automatic over-temperature and over-pressure protection
- Open door panels that slide upwards, saving space
- The compressor is powerful, operates stably, and operates with low noise
- Dust-proof and water-proof design effectively reduces maintenance cycle

Testing Conditions

24h icemaking test conditions:

room temperature 25 C,
water temperature 20 C.

In case of any discrepancy, the actual product shall prevail.

Available ice cube size

- Ice Cube Trays: 120
- 30x38x13 mm

Key Performance Indicators

- Design Life: 150,000 cycles
- Core Components Life: 5 years
- Annual Failure Rate: ≤1.5 times (field technical support provided)
- Water Output Error: ±5%
- Ice Discharge Temperature Error: ±3℃

Certifications available for this model



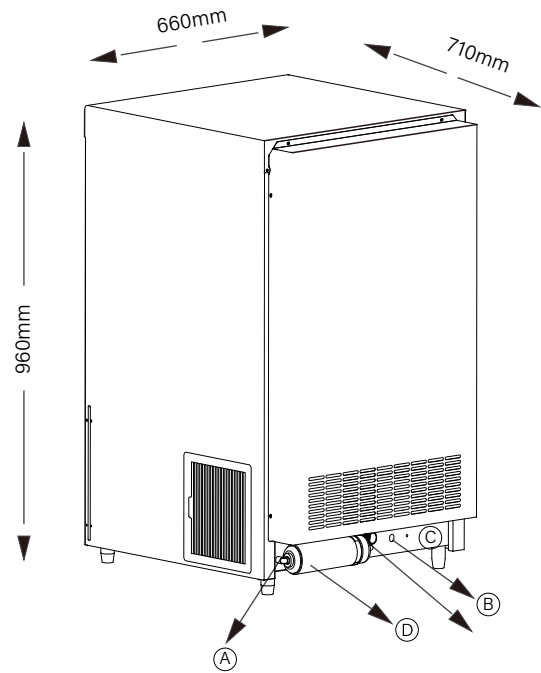
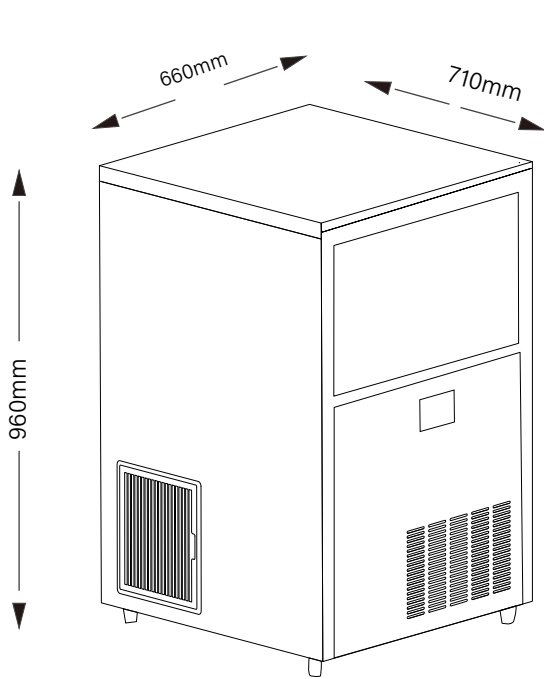
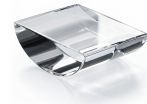

Connections

Ⓐ Ice making water inlet Ⓑ Drain Ⓒ Power Cord Ⓓ Water Filter

Technical information

Machine dimension	660x710x960 mm
Rated power/current	950W
Rated frequency	50Hz
24hour per day capacity	70kg/150lb
Refrigerant	R290

Machine Weigh	58kg
Rated voltage	220V
Inner liner capacity	36kg/94.9lb
Ice grids	30*38*13mm
Cooled type	Air-cooled

Storage and installation

Storage temperature: 5 to 50 °C Storage humidity: 10% to 70% Operating ambient temperature: 5 to 40 °C ambient humidity: 10% to 80%
 inlet water pressure: 1-5.5Bar Inlet water hardness: 0-8°DH Waterproof rating: IPX3

Implementation Standards

GB4706.1-2005/GB4706.36-2014 Production License Number: (Guangdong) XK01-302-1066

